



Tuxon-A



User's Manual

Ver. 1 / 2012 / 10

SAFETY PRECAUTION

WARNING

1. Use a lightning surge protector to avoid the risk or injury to operators and damage to instruments when lightning surge occurs frequently in the working environment.
2. Make sure the voltage of power supply is proper.
3. Ground the grounding terminal.
4. Carefully check all the wiring before the indicator is powered on.
- 5.** In the case of smoke, abnormal smell or strange sound, immediately cut off the power.

CAUTION

1. Please do not install the indicator directly in the following environments:
 - 1) Where the temperature or humidity exceeds allowed range.
 - 2) Where the indicator's main body is easily affected by vibrations.
 - 3) Where exist a mass of dust and powder, such as salt and iron power.
 - 4) Places containing caustic, flammable and explosive das.
 - 5) Where easily to be splashed by water, oil or chemicals.
2. Please take adequate shielding measures when the indicator is used at following locations:
 - 1) Near power lines
 - 2) Containing strong electrical field and magnetic field
 - 3) Where static or relay noise is generated.
3. Please cut off the power of Indicator before doing the following operations:
 - 1) Installation
 - 2) Wiring
 - 3)** Dismounting

CONTENTS

CONTENTS	4
1 General Description	1
1.1 General Description	1
1.2 Functions and Characteristics	1
1.3 Front Panel	1
1.4 Rear Panel	2
1.5 Technical Specifications	3
1.6 Dimensions of Indicator	4
2 Installation and Wiring	5
2.1 How to Install Indicator	5
2.2 Connection of Power Supply	6
2.3 Connection of Load Cell	6
2.3.1 6-wired Connection	6
2.3.2 4-wired Connection	7
2.4 Connection of Communication Interface	8
2.4.1 D/A Output Interface (Only for Tuxon-A)	8
3 Calibration	8
3.1 Instruction	8
3.2 Flow Chart of Calibration	9
3.2.1 Flow Chart of Calibration for Tuxon-A	9
3.3 Millivolt Value Display	11
3.4 Calibration with Weights	12
3.5 Calibration without Weights	12
3.5.1 Calibration without Weights for Tuxon-A	13
3.6 Explanation for Calibration Parameters	14
3.7 Log Table for Calibration Parameters	14
4 Working Parameters Setting	15
4.1 Flow Chart of Working Parameters Setting	15
4.1.1 Setting Flow Chart for Tuxon-A	15
4.2 Parameter Setting Method	16
4.2.1 Data Input Method	16
4.2.2 Option Selecting Method	16
5 Operation	18
5.1 Manual Zeroing	18
5.2 Display D/A Output Value (Only for Tuxon-A)	18
5.3 Password Input	19
5.4 Password Setting	20
6 Display Test	21
7 Error and Alarm Messages	22

1 General Description

1.1 General Description

Tuxon-A weighing transmitter is applied to transmit weight in industrial fields, which special features are small volume, plenty communicating commands, stable performance, easy operation and practicability, so it is widely used in concrete and bitumen mixing equipment, metallurgy furnace and converter, chemical industry and feed, etc. .

1.2 Functions and Characteristics

- Applicable to all kinds of resistance strain gauge bridge load cell.
- Front panel numerical calibration
- Multilevel of digital filter
- Automatic zero -tracking
- Automatically zero when powered on
- 16 Bits D/A output: 4-20mA, 0-20mA, 0-24mA, 0-5V, 0-10V, -5-5V or -10-10V

Selectable (for sub-model Tuxon A)

1.3 Front Panel

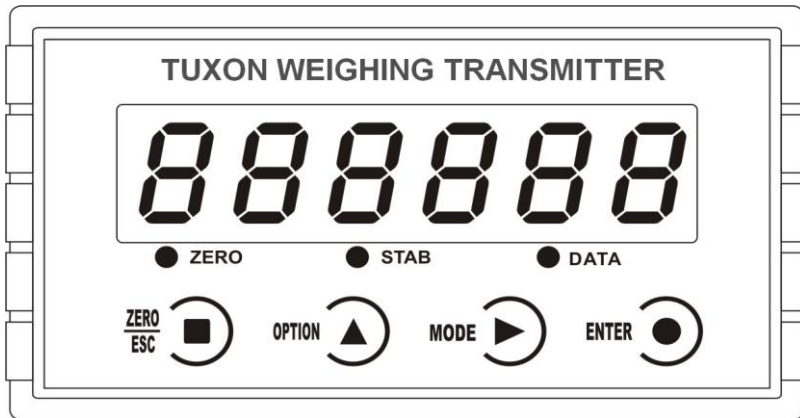

Keypad:



: **Zero/Esc.**

Zero Key: Used to clear display data.

Esc Key: Used to exit from current operation or go previous.



: **Option Key.** Used to scroll optional values of parameter.



And to make flashing digit increase 1 while data inputting.

: **Function Selecting Key.**

To make flashing position move to the right digit when data inputting.

: **Confirming Key.** Used to confirm present operation.

Status Indicator Lamp:

-
- **ZERO:** Light on when present weight is within $0 \pm 1/4d$.
 - **STAB:** Light on when changes of weight values are within the range of motion detecting during motion detecting time.
 - **DATA:** Light on when indicator displays the value of D/A output.

Main Display: 6 digits, for displaying weight, value of D/A output, and the information of parameters.

1.4 Rear Panel

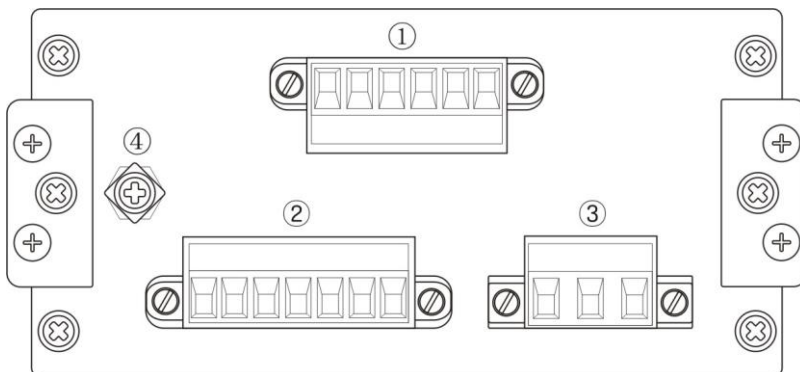

1. Serial Communication Connector/D/A Output Connector
2. Load Cell Connector
3. Power Supply Connector
4. Grounding Terminal

1.5 Technical Specifications

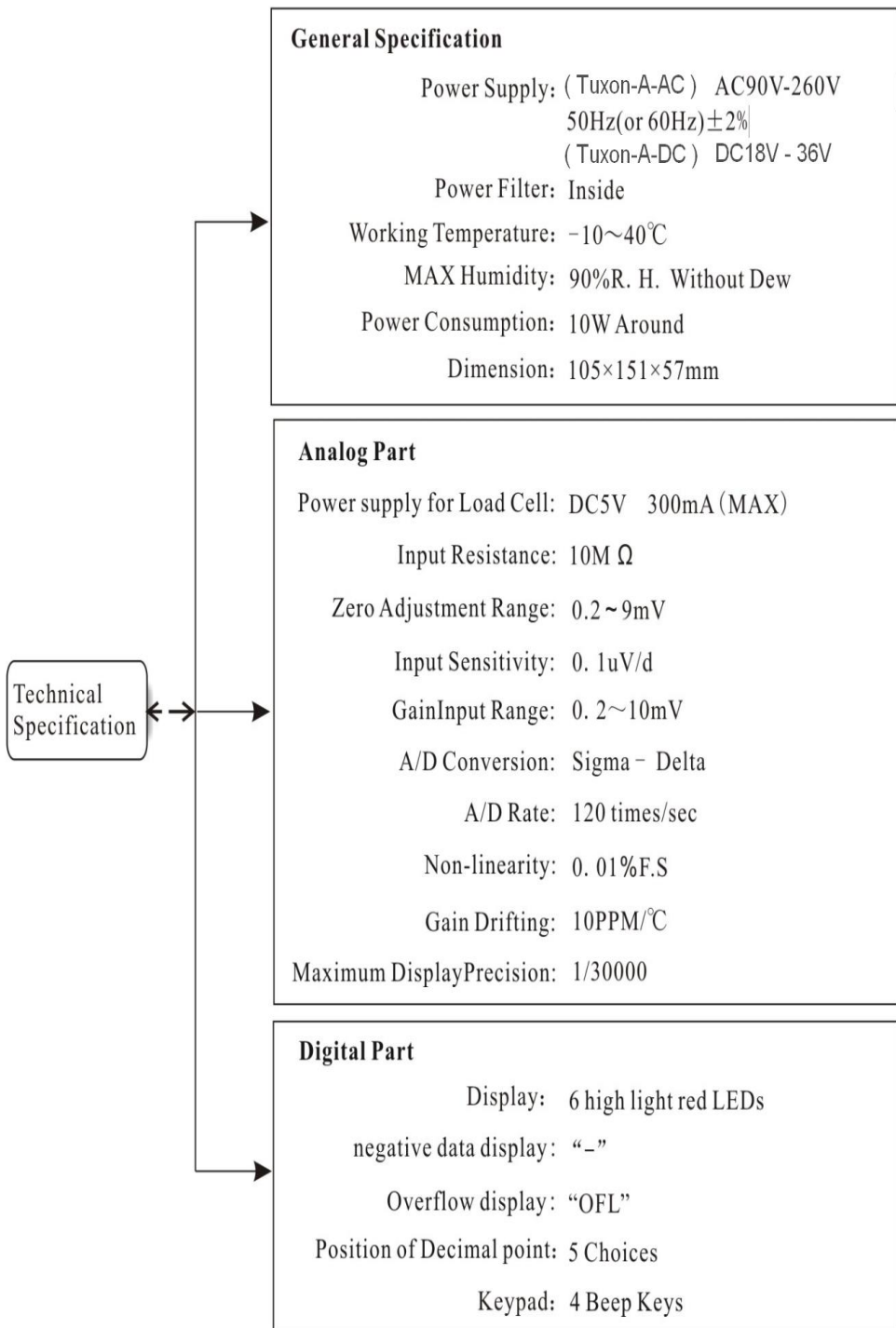

1.6 Dimensions of Indicator

Dimension of Front Panel

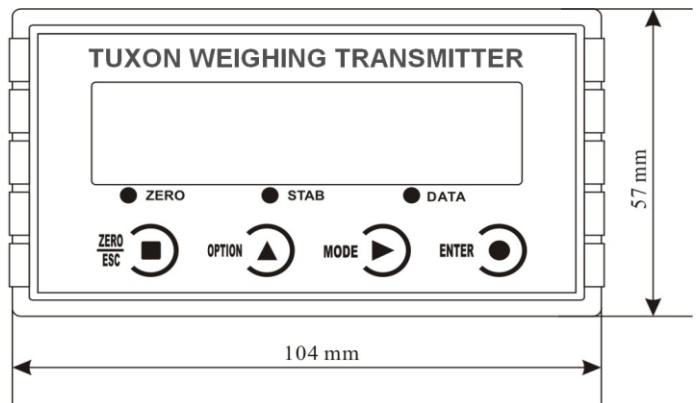

Dimension of Rear Panel

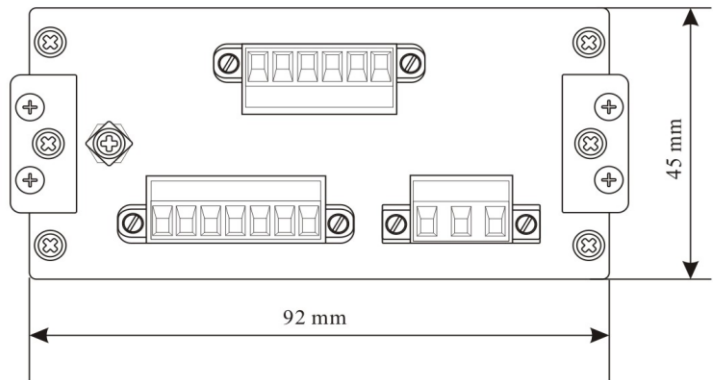

Side View Dimension

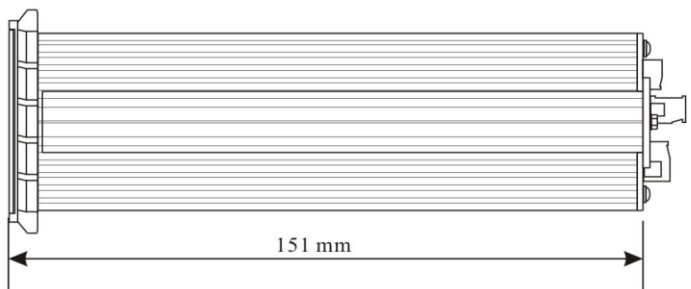

Panel Cutout Dimension

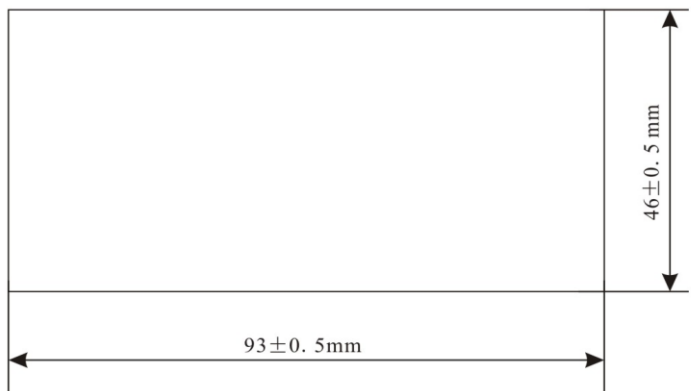

2 Installation and Wiring

2.1 How to Install Indicator

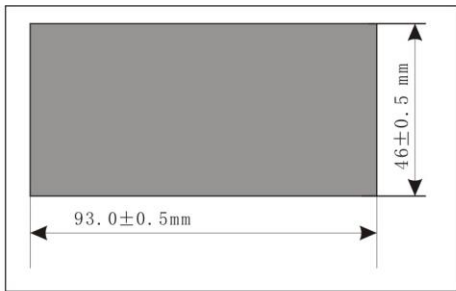

1. Make a cutout on the panel of control box according to the left dimension.

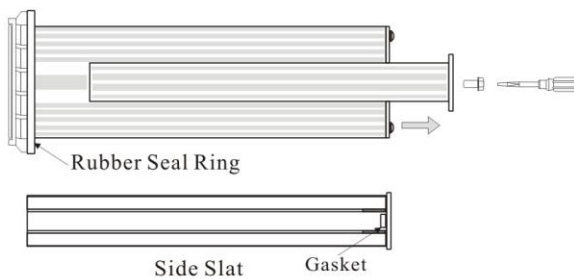

2. Unscrew the screws and take down the side slats.

Note: If there is no rubber seal ring, please take the gasket out.

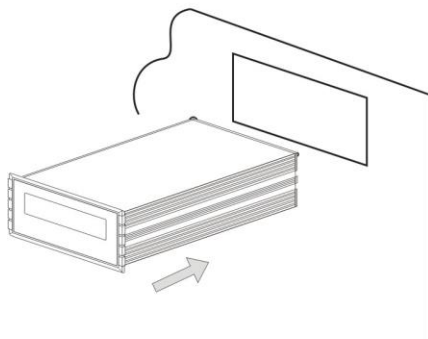

3. Install the indicator into the control box from front.

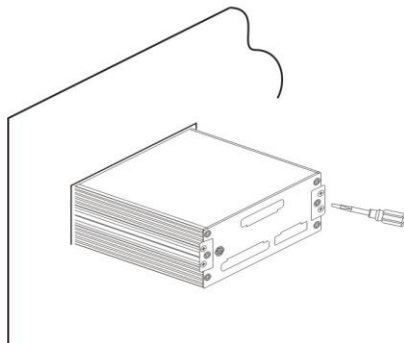

4. Insert the side slats into indicator and then lock them with screws.

2.2 Connection of Power Supply



- 1.AC power must have the grounding protection.
- 2.Do not connect the ground wire of indicator directly to the GND of other equipments.

2.3 Connection of Load Cell

Please refer to the picture below to connect load cells to Tuxon-A. When you use 4-wired load cells, you must bridge the SN+ with EX+ and bridge the SN- with EX-.

The signal definition of each port of the load cell connector is as follows:

Port	EX+	SN+	EX-	SN-	SIG+	SIG-	SHLD
Definition	Excitation+	Sense+	Excitation-	Sense-	Signal+	Signal-	Shield

2.3.1 6-wired Connection

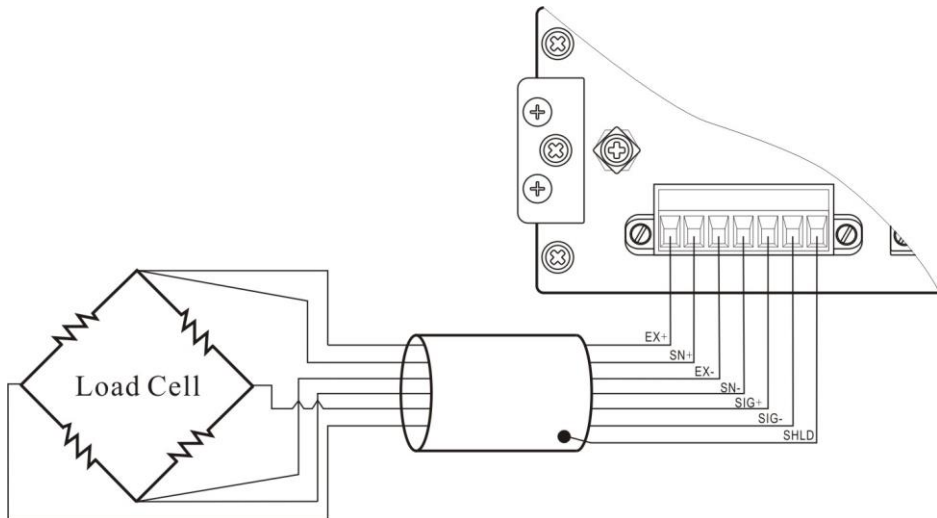

2.3.2 4-wired Connection

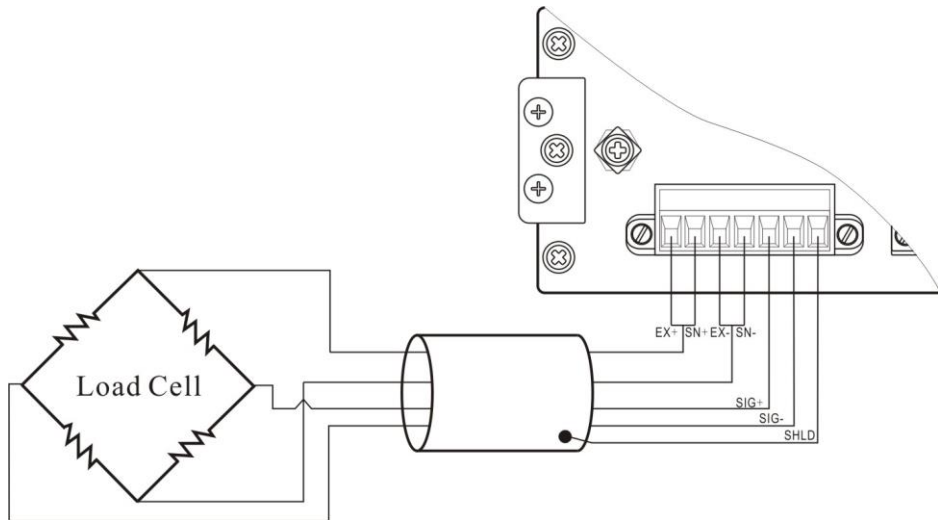

1. The signals from the load cells are low voltage analog signals, which are easily affected by electro-noise, so the cables connecting load cells to indicator should use shielded cables, and not bind with other cables, especially power supply cables.
2. For the application of short-transporting-distance and lower precision, 4-wired connection can be used; otherwise, 6-wired should be used.
3. Make sure EX+ bridges with SN+ and EX- bridges with SN- when 4-wire connection is used.
4. For the application of multi-load cell in parallel connection, the sensitivity of each load cell (mV/V) must be same.

2.4 Connection of Communication Interface

2.4.1 D/A Output Interface (Only for Tuxon-A)

D/A output contains 2 types, voltage-output type (0-5V, 0-10V, -5-5V, or -10-10V selectable) and current-output type (4-20mA, 0-20mA, or 0-24mA selectable).

The form of D/A output is decided by work parameter F1.1.

The signal definition of each port of D/A connector is as follows:

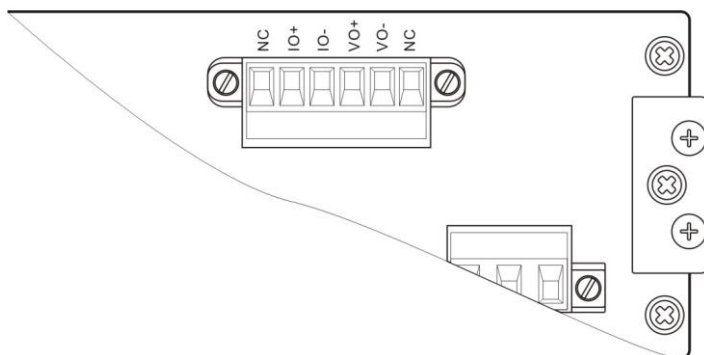

NC: Null; IO+: current-output +; IO-: current-output -;

VO+: voltage-output+; VO-: voltage-output-

3 Calibration

3.1 Instruction

(1) Calibration procedure must be executed when a Tuxon-A indicator is put in use at the first time, the preset parameters may no longer meet the user's needs, and any part of the weighing system was changed. Position of decimal point, minimum division, maximum capacity, zero, and gain can be set and confirmed through calibration.

(2) During calibration, if you want to skip one parameter to next one, press

directly. If you want to set only one parameter, please press  to save

parameter's value and then press  to exit.

(3) Please see section 3.6 for parameters' instruction.

(4) Please record each value in the blank table in section 3.7 during calibration for the emergency use in future.

(5) See chapter 8 for error alarm message that may be displayed during calibration.

3.2 Flow Chart of Calibration

3.2.1 Flow Chart of Calibration for Tuxon-A

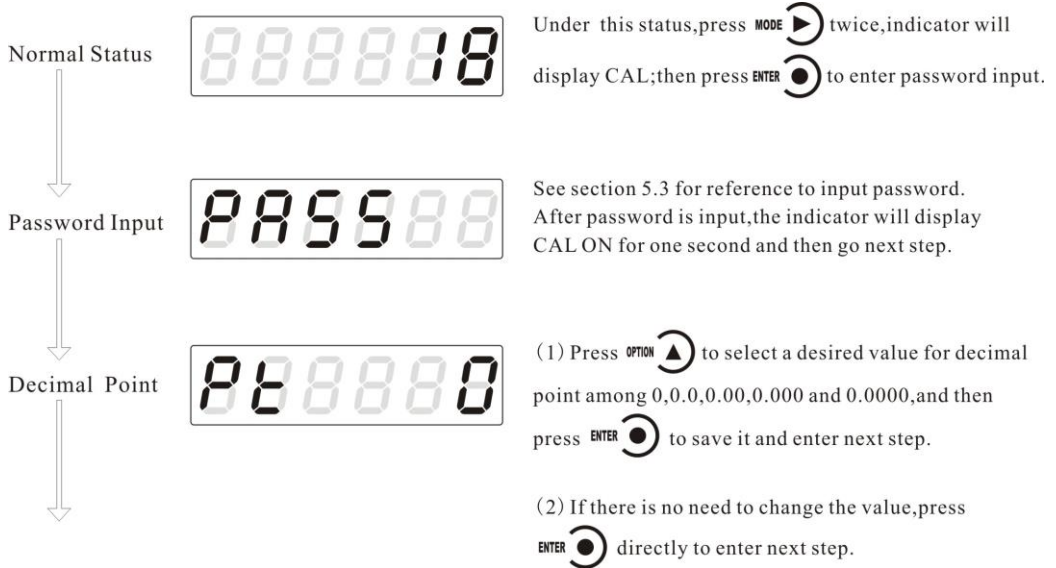

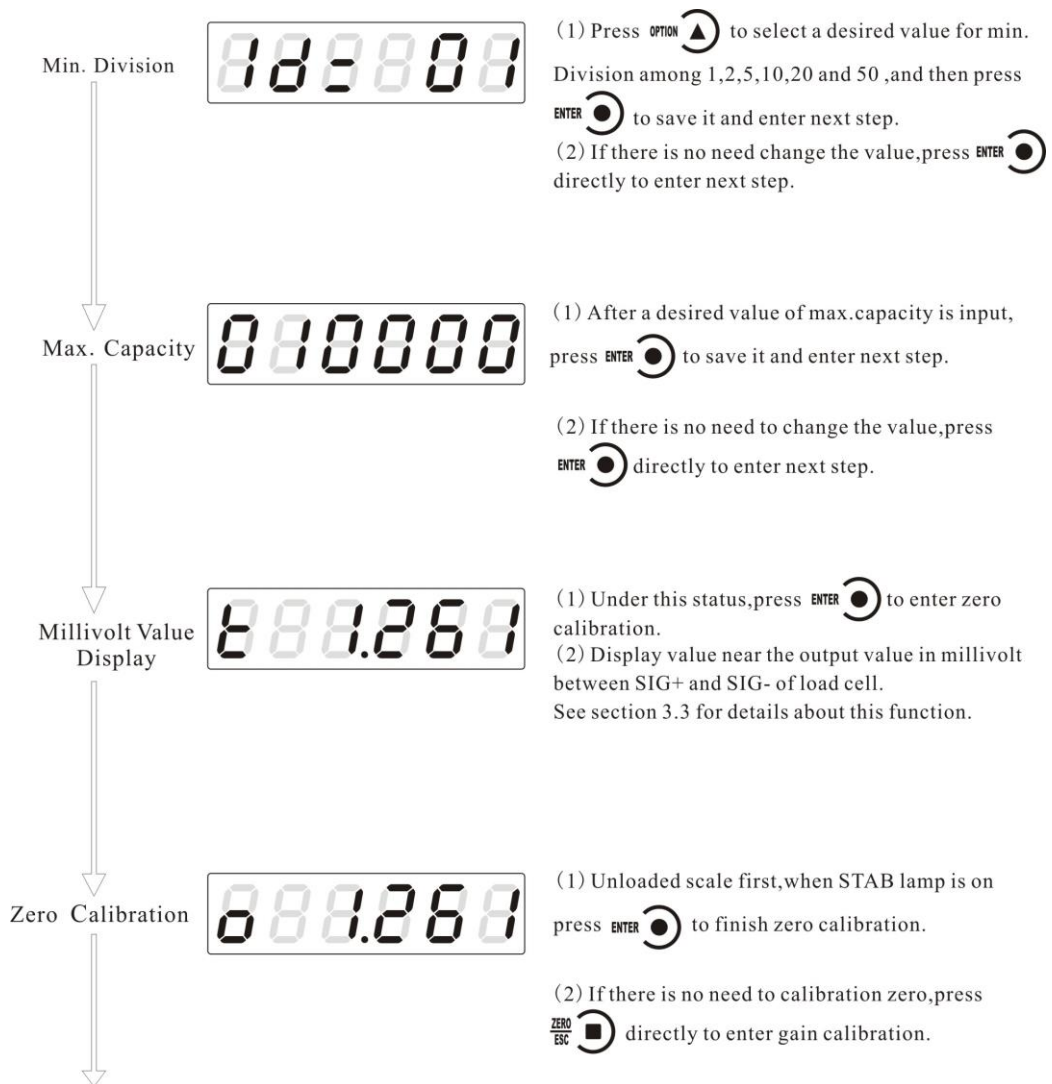

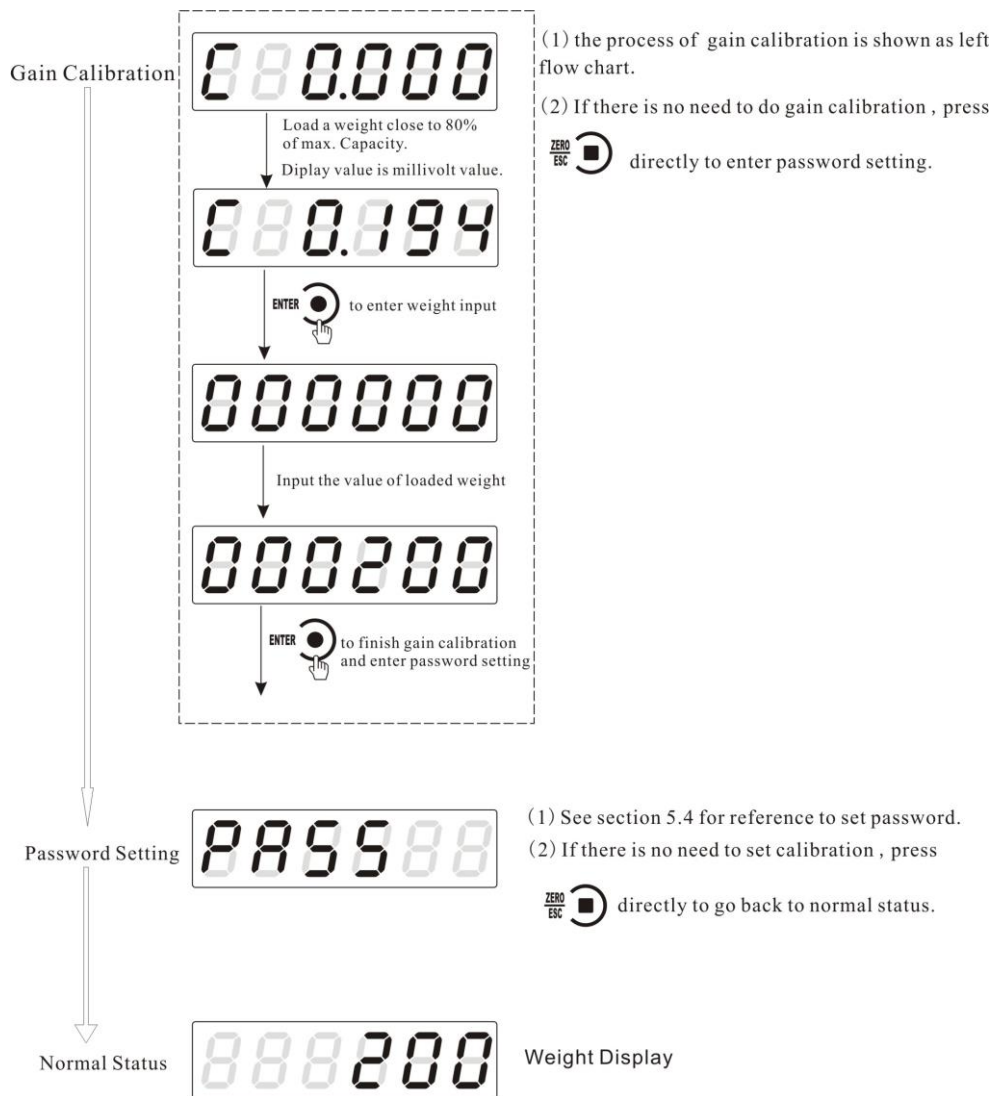

3.3 Millivolt Value Display

This function is mainly used for system test, position-error test for weighing mechanism and linearity test for load cell.

1. System Test

(1) If display data changes with loaded weight changes, it shows that connection of load cell is correct and weighing mechanism works well.

(2) If display value is OFL (or -OFL), it means that loaded weight on load cells is too large (or too small). Please unload the weight (or load more), if display value is still OFL (or -OFL), the possible reasons are as follows:

- a. There is something wrong with weighing mechanism, please check and clear.
- b. The connection of load cell is incorrect, please check and clear.
- c. Load cells may be damaged, please replace.

2. Position-error Test for Weighing Mechanism

Load a same weight on each corner of weighing mechanism and record displayed

millivolt value respectively. If differences among these values are obvious, please adjust weighing mechanism.

3. Linearity Test for Load Cell

Load same weight for several times, and record displayed value every time. If one or two values are obviously much larger or smaller than any others, it means that the linearity of load cell is bad.

***NOTE:** You must use  to zero display data before weight is loaded for each time.

3.4 Calibration with Weights

During calibration with weight, please record the zero millivolt value, gain millivolt value and the loaded weight value in the blank table below. If it is not convenient to load a weight to calibrate, these values can be used for calibration without weights.

	Zero millivolt value(mV)	Gain millivolt value(mV)	Loaded Weight	Date	Remarks
1					
2					
3					
4					
5					

3.5 Calibration without Weights

When it is not convenient to load a weight to calibrate, calibration can be done without weights using recorded data in the table in section 3.4. However, this method is just used for some emergencies, it will make calibration result incorrect if load cells, or indicator has been replaced.

3.5.1 Calibration without Weights for Tuxon-A

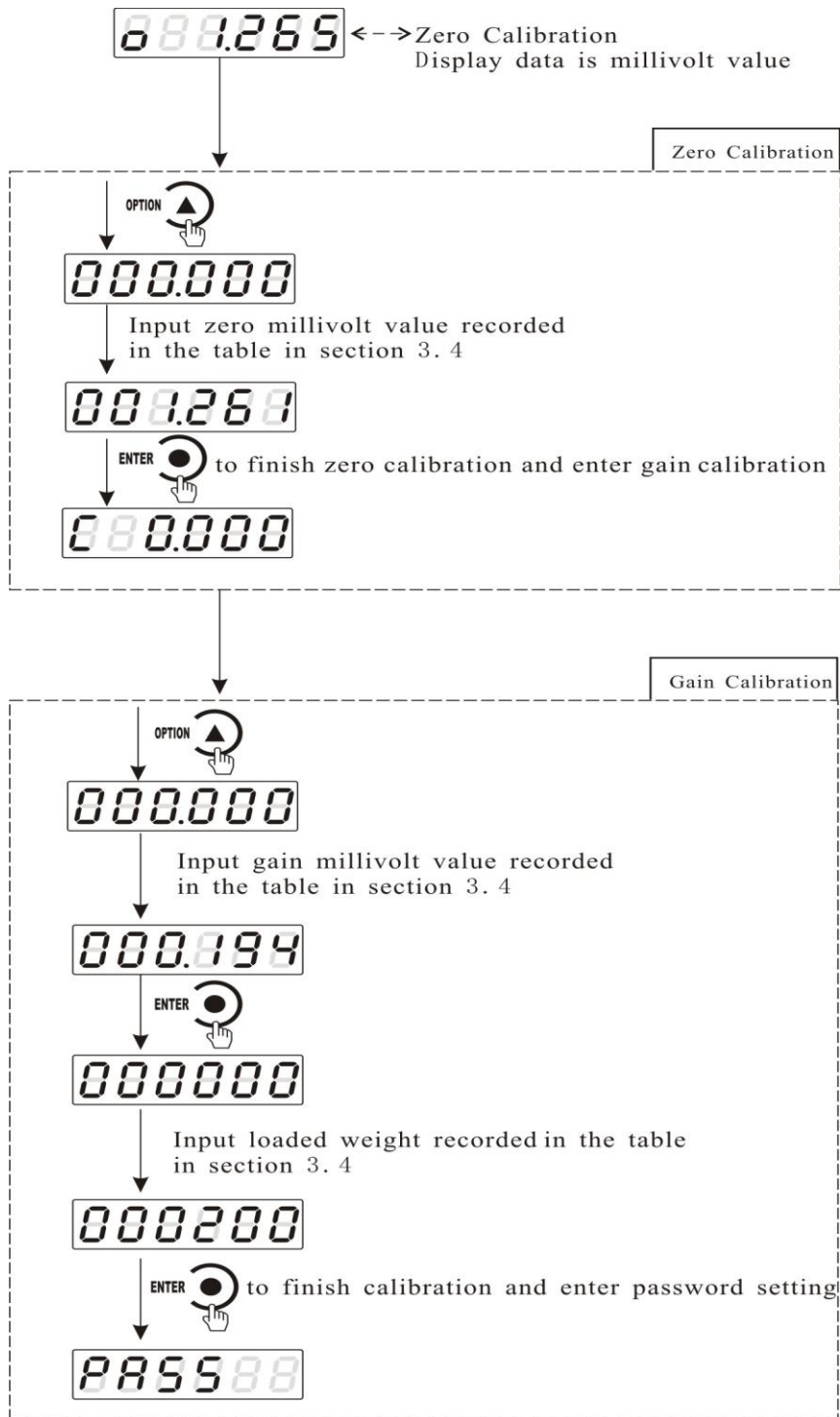

3.6 Explanation for Calibration Parameters

Symbol	Parameter	Value of parameter	Default
Pt	Decimal Point	0/ 0.0/ 0.00/ 0.000 /0.0000	0
1d=	Min. Division	1/ 2/ 5/10/20 /50	1

CP	Max. Capacity	$\leq \text{Min. Division} \times 30000$	10000
t	Millivolt Value		
o	Zero		
c	Gain		
	Switch for Calibration Via Serial Interface (only for Tuxon-S)		
	Password Setting		

3.7 Log Table for Calibration Parameters

Parameter	Calibrated Value	Date	Remarks
Decimal Point			
Min. Division			
Max. Capacity			
Password			

4 Working Parameters Setting

4.1 Flow Chart of Working Parameters Setting

4.1.1 Setting Flow Chart for Tuxon-A

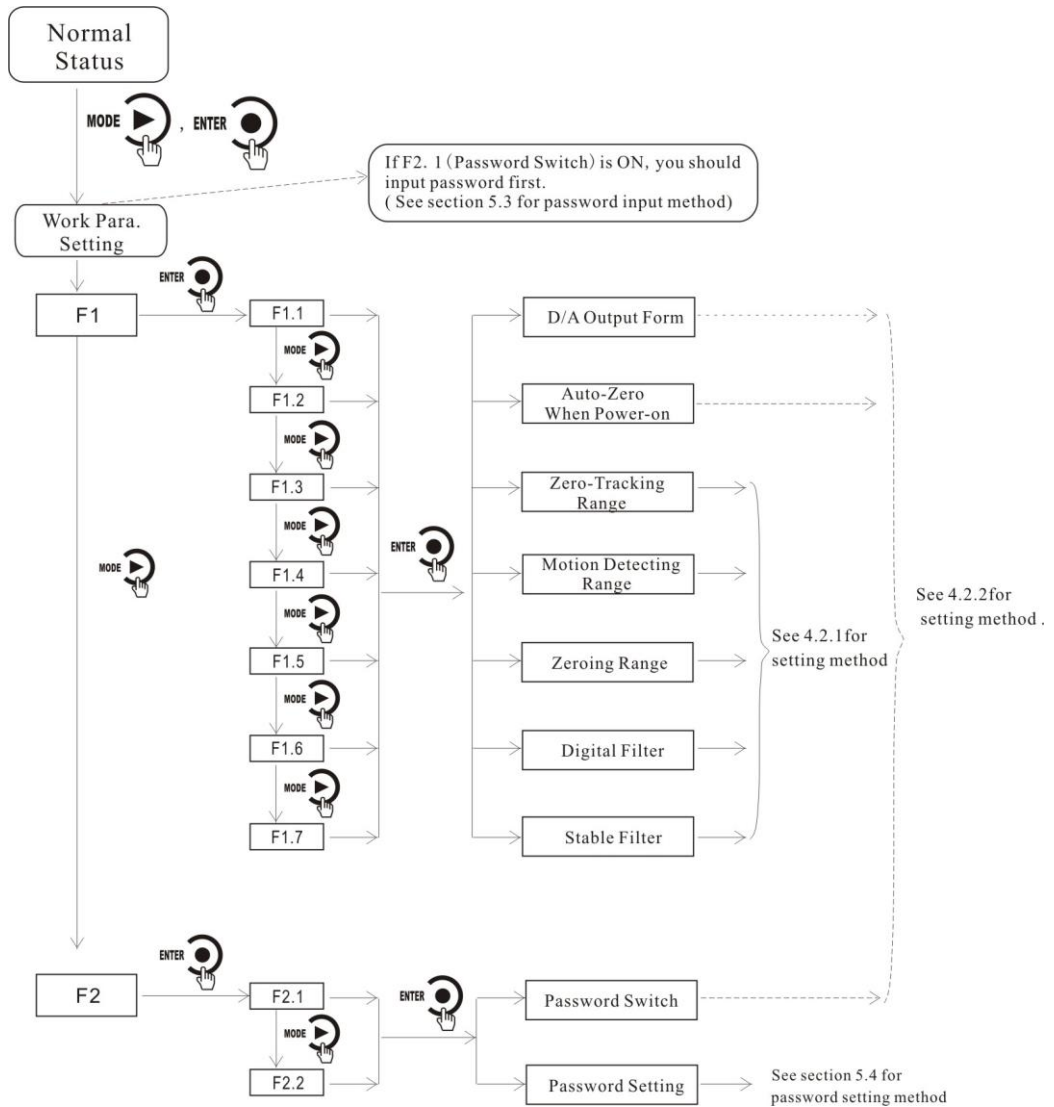

4.2 Parameter Setting Method

4.2.1 Data Input Method

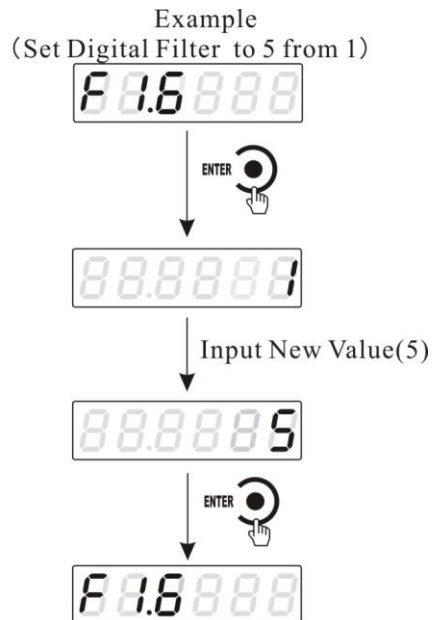
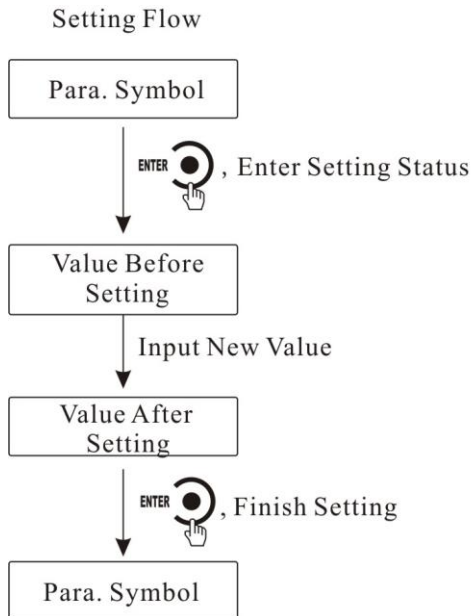

4.2.2 Option Selecting Method

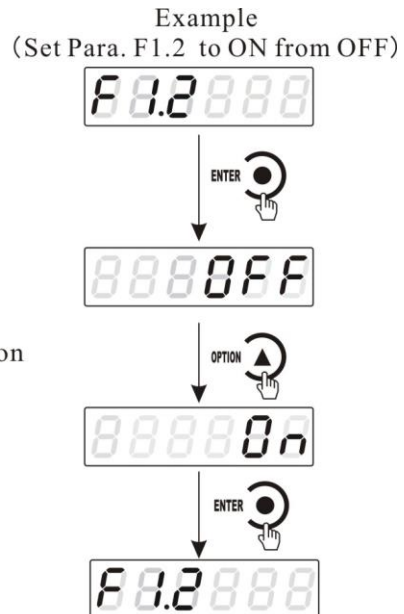
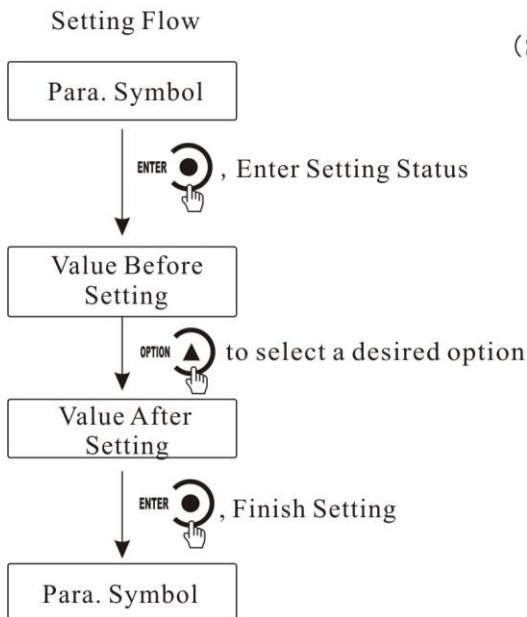

4.3 Descriptions of Working Parameters

Code	Parameter	Default	Description
F1	Null	Null	The first major term of working parameter.
F1.1	4-20/0-20/ 0-24/0-5/ 0-10/-5-5/ -10-10/ USEr	4-20	The analog output form : 4-20: 4-20mA; 0-20: 0-20mA; 0-20: 0-24mA; 0-5: 0-5V; 0-10: 0-10V; -5-5: -5-5V; -10-10: -10-10V; USEr: user-defined analog output
F1.2	ON/ OFF	OFF	Switch for Auto-Zeroing when power-on, OFF: disabled ON: enabled
F1.3	0~9	0	Zero-tracking Range (0~9d optional) . This parameter is for automatic calibration, disabled when is set "0".
F1.4	1~9	1	Motion Detecting Range (1~9d optional) ;
F1.5	00~99	50	Zeroing Range (00%~99% of Maximum capacity) ;
F1.6	0~9	5	Digital filtering parameter: 0: without filtering 9: strongest digital filtering
F1.7	0~9	0	Stable filter parameter (the second filter based on the first filter) : 0: without filtering 9: strongest digital filtering
F2	Null	Null	The second major term of working parameter.
F2.1	ON/OFF	OFF	Password Switch
F2.2		000000	Password Setting; Enabled when parameter F2.1 is set "ON".
F3	Null	Null	user-defined parameters of analog quantity (Display when the parameter F1.1 is chosen "USEr".
F3.1	IOUT/ VOUT	IOUT	Chose the analog output mode

F3.2	0~24000或- 10000~10000	000000	Minimum analog quantity output. If parameter F3.1 is chosen “ IOUT ”, then setting range is 0~24000 ; If parameter F3.1 is chosen “ VOOUT ”, then setting range is “ -10000~10000 ”and so on.
F3.3	F3.2~24000/ F3.2~10000	000000	The analog output value when zero.
F3.4	F3.3~24000/ F3.3~10000	000000	The when Maximum capacity.
F3.5	F3.4~24000/ F3.4~10000	000000	The Maximum analog output value.

Notice:

1. Setting method of “minus” in parameter **F3.2**: When not “0” condition, press  to switchover “0/-” and then make choice for “+/- ” on the top digit.
2. Setting in sequence: **F3.2~F3.5** and **F3.2<=F3.3<<F3.4<=F3.5** .

5 Operation

5.1 Manual Zeroing

Under normal status, press  to clear display data to zero.

Explanation for error display during manual zeroing:

“Error 2”: Current weight is not within the zeroing range.

“Error 3”: Display (system) is not stable.

5.2 Display D/A Output Value (Only for Tuxon-A)

Under normal status, press  to make display content toggle between

weight and D/A output value, the DATA indicator lamp will be on when display content is D/A output value.

5.3 Password Input

1. The default passwords of calibration and working parameters setting are: 000000
2. As being protected by password, you must input the password before calibration.

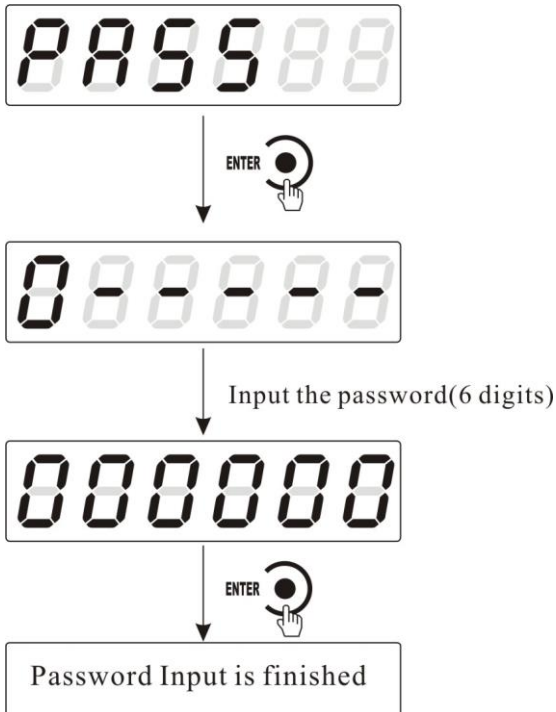

During password inputting procedure, indicator will display “0 = = = =” after a wrong password is input once, and will display “0 = = = =” after twice, and will display “Error 4” and be locked after 3 times.

You must reboot the indicator to unlock it and make it work well when it displays “Error 4”.

5.4 Password Setting

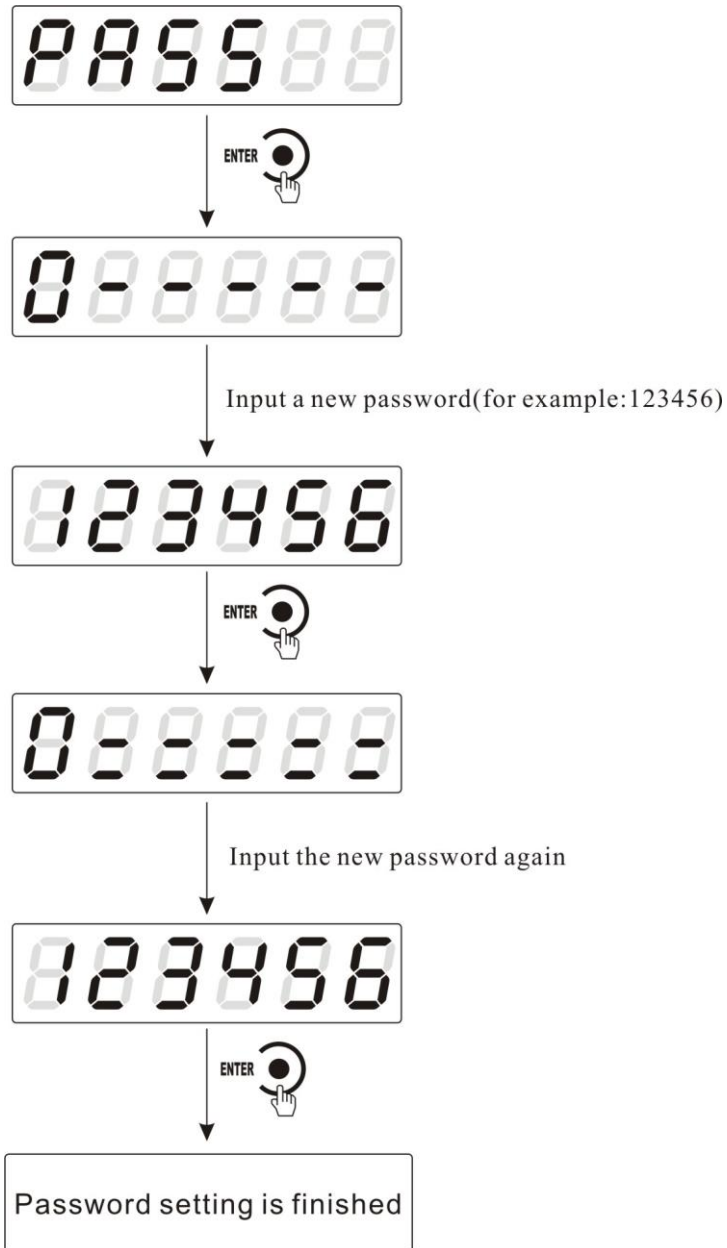

***Note: If passwords input second time does not match the first time, indicator will display “Error” for one second and return to “PASS” interface.**

6 Display Test

Under normal status, display test is shown in flow chart below. If the test result is the same as flow chart, it means that display and indicator lamps all work well.

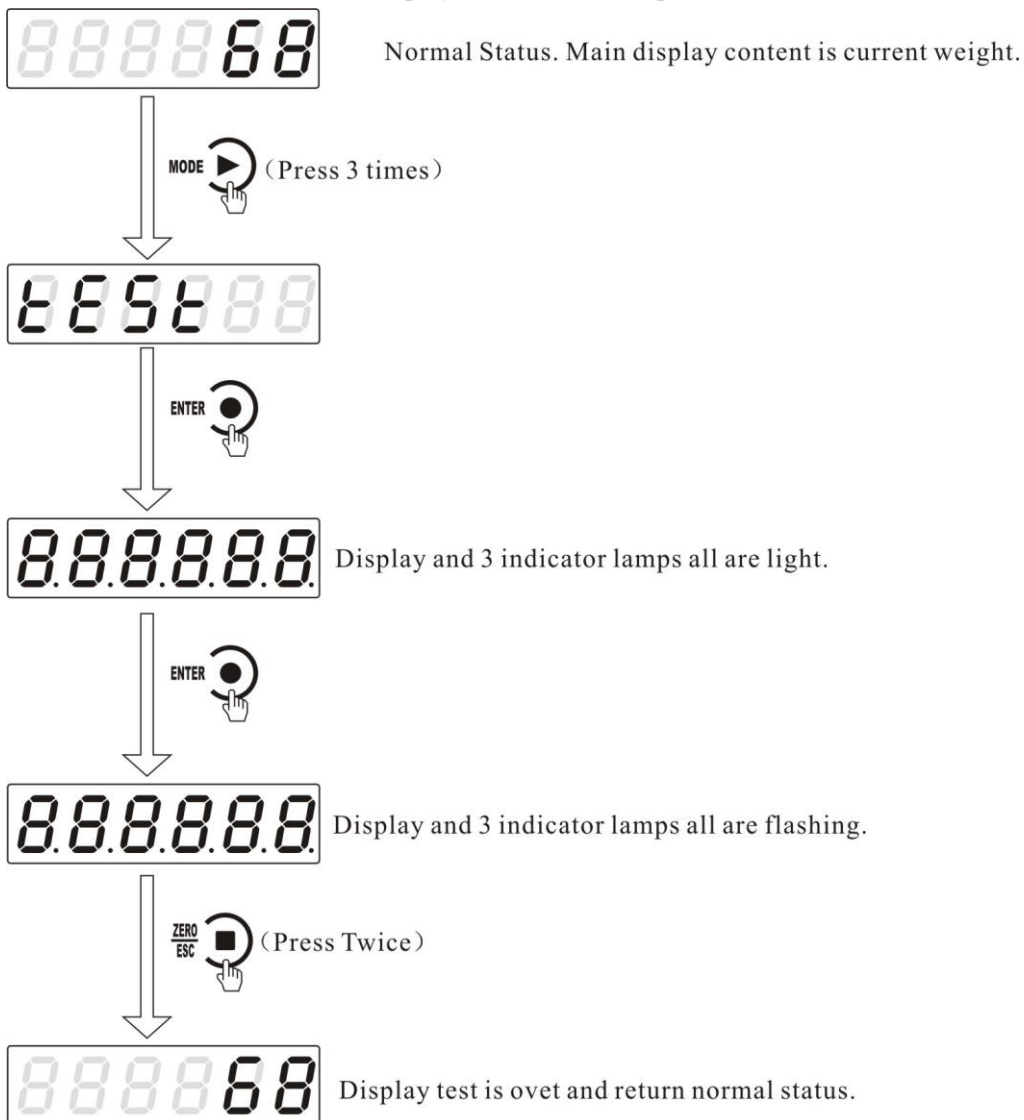

7 Error and Alarm Messages

ERROR : Incorrect data input.

ERROR2: Current weight is not within the zeroing range when zeroing.

ERROR3: Display (system) is not stable when zeroing

ERROR4: Password input is wrong for **3** times.

-OFL/ OFL: Weighing result overflows

OVER: The output signal of load cell is too large while doing zero calibration.

UNDER: The output signal of load cell is too small while doing zero calibration.